

## Instructions for use



CE  
0297

PEOPLE HAVE PRIORITY



proxeo<sup>ULTRA</sup>

**Handpiece**  
PB-5 L, PB-5 L S, PB-5 L Q

# Contents

---

<b>Symbols</b> .....	4
in the Instructions for use .....	4
on the medical device .....	5
packaging.....	6
<b>1. Introduction</b> .....	7
<b>2. Safety notes</b> .....	10
<b>3. Product description</b> .....	15
<b>4. Operation</b> .....	16
Assembly/Removal .....	16
Changing the tip .....	17
Test run .....	20
<b>5. Hygiene and maintenance</b> .....	21
General notes .....	21
Limitations on processing.....	23

Initial treatment at the point of use.....	24
Manual cleaning.....	25
Manual disinfection .....	29
Automated cleaning and disinfection.....	30
Drying .....	31
Inspection, Maintenance and Testing.....	32
Packaging.....	34
Sterilization .....	35
Storage.....	38
<b>6. Exchanging the supply hose O-rings.....</b>	<b>39</b>
<b>7. Servicing.....</b>	<b>40</b>
<b>8. W&amp;H Accessories and spare parts.....</b>	<b>41</b>
<b>9. Technical data.....</b>	<b>42</b>
<b>10. Disposal.....</b>	<b>44</b>
<b>Explanation of warranty terms.....</b>	<b>45</b>
<b>Authorized W&amp;H service partners .....</b>	<b>47</b>



**WARNING!**  
(risk of injury)



**ATTENTION!**  
(to prevent  
damage occurring)



General explanations,  
without risk to  
persons or objects



Do not dispose of  
with domestic waste



Type B applied part  
(not suitable for  
intracardiac application)

## Symbols

on the medical device



CE marking  
with identification number  
of the Notified Body



DataMatrix Code  
for product information  
including UDI (Unique  
Device Identification)



Data structure in  
accordance with  
Health Industry Bar Code



Catalogue number



Thermo washer  
disinfectable



Serial number



Sterilizable up to the  
stated temperature



Date of manufacture



Suitable for people with  
pacemakers or implanted  
defibrillators

Thread system:



Q-Link



W&H



Satelec



CE marking  
with identification number  
of the Notified Body



DataMatrix Code  
for product information  
including UDI (Unique  
Device Identification)



Data structure in  
accordance with  
Health Industry Bar Code



Caution! According to Federal law, this medical device may only be sold by or on the order of a dentist, physician or any other medical practitioner licensed by the law of the State in which he or she practices and intends to use or order the use of this medical device.

## 1. Introduction

---

Customer satisfaction has absolute priority in the W&H quality policy. This medical device has been developed, manufactured and subjected to final inspection according to legal regulations, quality and industry standards.

### **For your safety and the safety of your patients**

Prior to initial use please read the Instructions for use. These explain how to use your medical device and guarantee a smooth and efficient operation.



Observe the safety notes.

### **Intended use**

Drive unit with a piezoceramic oscillating system, which moves the tip in a linear oscillation. The drive unit is used for the removal of supragingival calculus and subgingival concretions and for endodontics application and preparation of tooth enamel.



Misuse may damage the medical device and hence cause risks and hazards for patient, user and third parties.

### **Qualifications of the user**

We have based our development and design of the medical device on the dentists, dental hygienists, dental employees (prophylaxis) and dental assistants target group.



### **Production according to EU Directive**

The medical device meets the requirements of Directive 93/42/EEC.

### **Responsibility of the manufacturer**

The manufacturer can only accept responsibility for the safety, reliability and performance of the medical device when it is used in compliance with the following directions:

- > The medical device must be used in accordance with these Instructions for use.
- > The medical device has no components that can be repaired by the user.
- > Modifications or repairs must only be undertaken by an authorized W&H service partner (see page 47).
- > Unauthorized opening of the medical device invalidates all claims under warranty and any other claims.



**Skilled application**

The medical device is intended only for skilled application according to the intended use as well as in compliance with the valid health and safety at work regulations, the valid accident prevention regulations and in compliance with these Instructions for use.

The medical device should be prepared for use and maintained by staff who have been trained in procedures for infection control, personal safety and patient safety.

Improper use, unauthorized assembly, modification or repair to the medical device, non-compliance with our instructions or the use of accessories and spare parts which are not approved by W&H, invalidates all claims under warranty and any other claims.

## 2. Safety notes

---



- > Before using the medical device for the first time, store it at room temperature for 24 hours.
- > Always ensure the correct operating conditions and cooling function.
- > Always ensure that sufficient and adequate cooling is delivered and ensure adequate suction (except for tips where no coolant is used).
- > In case of coolant supply failure, the medical device must be stopped immediately (maximum operating time without coolant is 30 seconds). The exception are applications where no coolant is used (e.g. endodontics). Maximum operating time without coolant is 2 minutes.
- > Check the medical device for damage and loose parts each time before using (e.g., tip, handpiece cap).
- > Do not operate the medical device if it is damaged.
- > Perform a test run each time before using.
- > Do not look directly into the optic outlet.
- > Run the rinse function for the dental unit once per day.
- > Replace damaged or leaking O-rings immediately.
- > Do not twist, kink or squeeze the supply hose (risk of damage).



## Tips

- > Only use tips that have been approved by W&H and the associated tip changers or spanners.
- > An overview of the correct power settings is included with every tip.
- > With periodontal tips, the medical device is suitable for the removal of concretions in the subgingival region, but not for applications which demand sterile conditions. Choose the lower performance range when carrying out periodontal treatments on hypersensitive patients in order to guarantee optimum pain-free treatment.
- > Ensure that the original shape of the tips is not affected (e.g. by being dropped).
- > The tips must not be bent back into shape or resharpened.
- > Locate and secure the tip only with the medical device switched off.
- > Never touch the tips when vibrating.
- > Insert the tip changer onto the inserted tip of the stationary medical device after every treatment (protection against injury and infection, tip protection). Tips that are changed using a spanner must be removed from the medical device immediately after treatment.
- > Do not touch into the tip changer (with tip inserted).
- > Check for the effect of wear on the tips using the accompanying tip card.
- > Change tips if there are visible signs of wear.



### **Approved coolants and rinsing liquids**

- > Physiological saline solution (NaCl, 0.9%)
- > Hydrogen peroxide ( $H_2O_2$ , 1–3%)
- > Liquids with the active substance chlorhexidine (CHX, 0.2%)
- > Tap water



The medical device is tailored to the W&H supply hose and the W&H control electronics and must therefore only be used with W&H products. Using other components could lead to deviating parameters or even the destruction of the system.



**Risks due to electromagnetic fields**

This medical device complies with the reference values defined in EN 50527-2-1/2016 for active implantable medical devices (AIMD) and cardiac pacemakers.



The medical device is not approved for operation in potentially explosive atmospheres.

## Hygiene and maintenance prior to initial use



- > The medical device is not sterilized when delivered.
- > The packaging is non-sterilizable.
  
- > Clean and disinfect the medical device, the tips and the tip changer.
- > Sterilize the medical device, the tips and the tip changer.

### 3. Product description

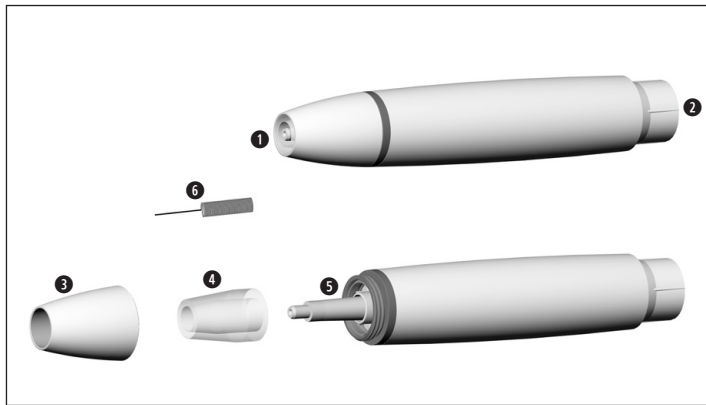

- ① Thread
- ② Connection for supply hose
- ③ Handpiece cap
- ④ Optical fibre
- ⑤ Optic outlet
- ⑥ Nozzle cleaner

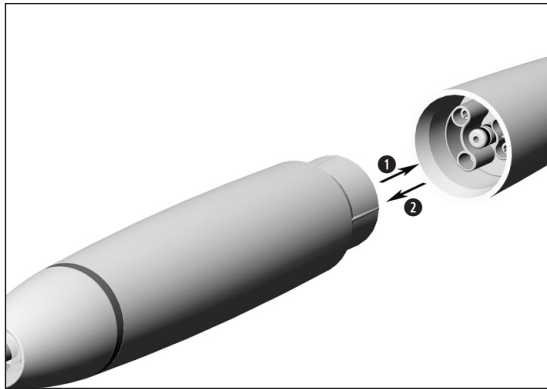

❶ Push the medical device onto the supply hose.

 Note the positioning.

❷ Remove the medical device.



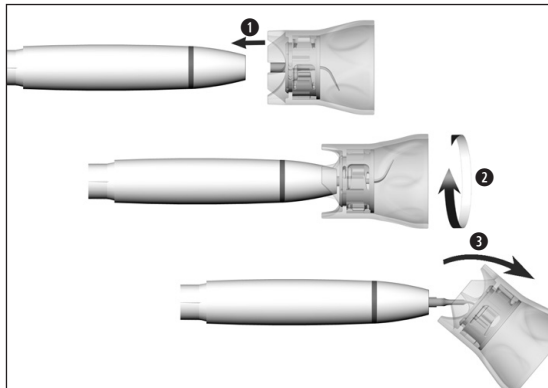

### Insert tip with tip changer



Ensure the matching thread system  
(at the handpiece, tip changer, tip)!

- 1 Position the tip on the thread of the medical device.
- 2 Turn the tip changer until it audibly engages.
- 3 Withdraw the tip changer.



Verify full engagement.



Press the tip with about 1 N (= 100 g)  
pressure onto a firm object to test the  
loading capacity of the tip.

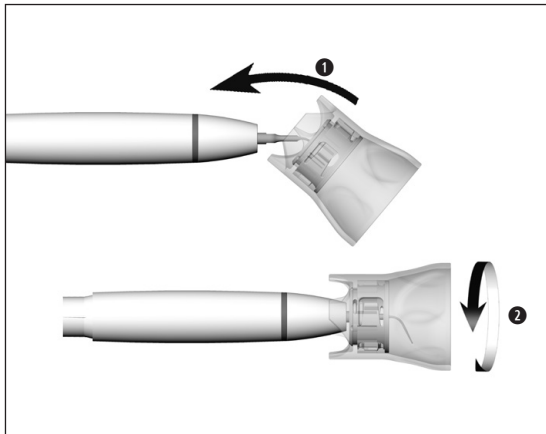

## Remove tip with tip changer

- 1 Place the tip changer onto the tip.
- 2 Unscrew the tip with the tip changer.



Leave the tip in the tip changer until the hygienic maintenance process!

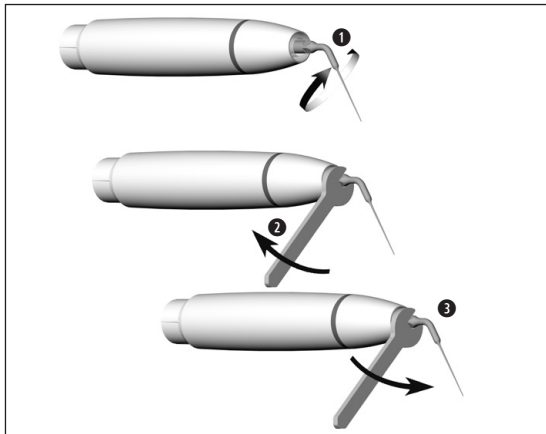

## Insert/remove tip with spanner

- ➊ Position the tip on the thread of the medical device.
- ➋ Screw the tip down.



Verify full engagement.

- ➌ Unscrew the tip.

## Test run





Do not hold the medical device at eye level!

- > Attach the medical device to the supply hose.
- > Insert the tip.
- > Put the medical device into operation.



In the event of operating malfunctions (e.g. vibrations, unusual noise, overheating, coolant supply failure or leakage) **stop the medical device immediately** and contact an authorized W&H service partner.

 Follow your local and national laws, directives, standards and guidelines for cleaning, disinfection and sterilization.

 > Wear protective clothing, safety glasses, face mask and gloves.

 > Use only oil-free, filtered compressed air with a maximum operating pressure of 3 bar for manual drying.

## Cleaning agents and disinfectants



- > Read the notes, follow the instructions and heed the warnings provided by the manufacturers of cleaning agents and/or disinfectants.
- > Use only detergents which are intended for cleaning and/or disinfecting medical devices made of metal and plastic.
- > It is imperative to comply with the concentrations and exposure times specified by the manufacturer of the disinfectant.
- > Use disinfectants which have been tested and found effective by the Verbund für Angewandte Hygiene e.V. (VAH = Association for Applied Hygiene), the Österreichischen Gesellschaft für Hygiene, Mikrobiologie und Präventivmedizin (ÖGHMP = Austrian Society for Hygiene, Microbiology and Preventive Medicine), the Food and Drug Administration (FDA) and the U.S. Environmental Protection Agency (EPA).



The user is responsible for validating its process if the specified cleaning agents and disinfectants are not available.



The product lifetime and the medical device's ability to operate correctly are mainly determined by mechanical stress during use and chemical influences due to processing.

- > Send worn or damaged medical devices and/or medical devices with material changes to an authorized W&H service partner.

### Processing cycles



- > We recommend a regular service for the W&H medical device after 500 processing cycles or one year.
- > We recommend to replace the tip changer after 250 processing cycles.
- > Check signs of wear on the tips (see tip card).



Clean the medical device immediately after every treatment, to flush out liquid (e.g., blood, saliva etc.) and to prevent settling on the internal parts.

- > Operate the medical device for at least 10 seconds at idle speed.
- > Ensure that all coolant outlets are rinsed out.



- > Wipe the entire surface of the medical device, the tip and the tip changer with disinfectant.
- > Remove the tip.
- > Remove the medical device.



Note that the disinfectant used during pre-treatment is only for personal protection and cannot replace the disinfectant step after cleaning.



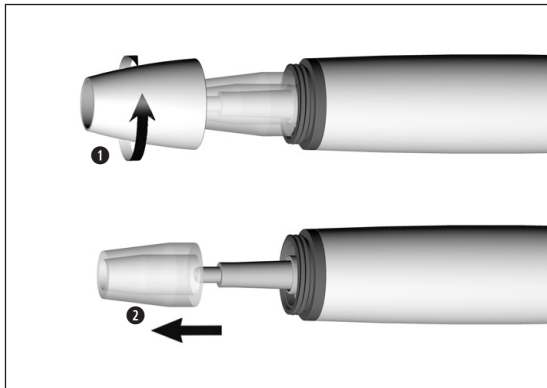



### Disassembling the medical device

- 1 Unscrew the handpiece cap.
- 2 Remove the optical fibre.

 Do not place the medical device and the tip changer in liquid disinfectant or in an ultrasonic bath.

 Clean and disinfect diamond coated tips in an ultrasonic bath.

 Evidence of the tips basic suitability for effective manual cleaning and disinfection was provided by an independent test laboratory using the »Bandelin Type RK 100 CC« ultrasonic bath and the cleaning agent and disinfectant »StammopurDR8 [DR H Stamm, Berlin]«.

- > Clean the medical device under running tap water (< 35°C/< 95°F).
- > Rinse and brush off all internal and external surfaces.
- > Remove liquid residues using compressed air.

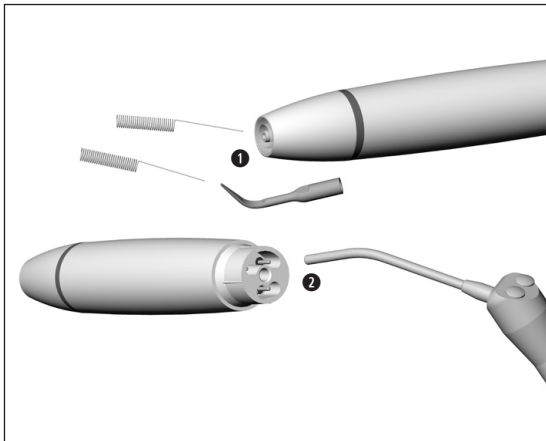

### Cleaning the spray nozzles

- 1 Clean coolant outlets carefully with the nozzle cleaner to remove dirt and deposits.



The nozzle cleaner can be cleaned in an ultrasonic bath and/or in the washerdisinfector.

### Cleaning the coolant tube

- 2 Blow through the coolant tube using compressed air.



In the case of clogged up coolant outlets or coolant tubes contact an authorized W&H service partner.

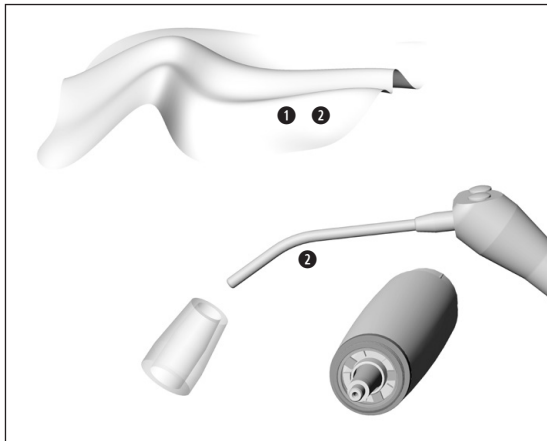

## Cleaning the optic outlet and the optical fibre



Avoid scratching the optic outlet and the optical fibre!

- ① Wash the optic outlet and the optical fibre with cleaning fluid and a soft cloth.
- ② Blow the optic outlet and the optical fibre dry using compressed air or dry it carefully with a soft cloth.



- > Carry out a visual inspection after each cleaning process.
- > Do not use the medical device if the optic outlet or the optical fibre is damaged and contact an authorized W&H service partner.



> W&H recommends wiping down with disinfectant.



Evidence of the medical device's, the tips' and the tip changer's basic suitability for effective manual disinfection was provided by an independent test laboratory using the »mikrozid® AF wipes« disinfectant [Schülke & Mayr GmbH, Norderstedt].



W&H recommends automated cleaning and disinfection using a washer-disinfector (WD).

- > Read the notes, follow the instructions and heed the warnings provided by the manufacturers of washer-disinfectors, cleaning agents and/or disinfectants.



Evidence of the basic suitability of the medical device, the tip and the tip changer for effective automated disinfection was provided by an independent test laboratory using the »Miele PG 8582 CD« washer-disinfector (Miele & Cie. KG, Gütersloh) and the »Dr. Weigert neodisher® MediClean forte« cleaning agent (Dr. Weigert GmbH & Co. KG, Hamburg) according to ISO 15883.

- > Cleaning at 55°C (131°F) – 5 minutes
- > Disinfection at 93°C (200°F) – 5 minutes

### Mechanical cleaning and disinfection of the tips



Use the Miele A 814 adapter.



- > Ensure that the medical device, the tip and the tip changer are completely dry internally and externally after cleaning and disinfection.
- > Remove liquid residues using compressed air.

### Inspection



- > Check the medical device, the tip and the tip changer after cleaning and disinfection for damage, visible residual soiling and surface changes.
- > Reprocess any medical devices, the tip and the tip changer that are still soiled.



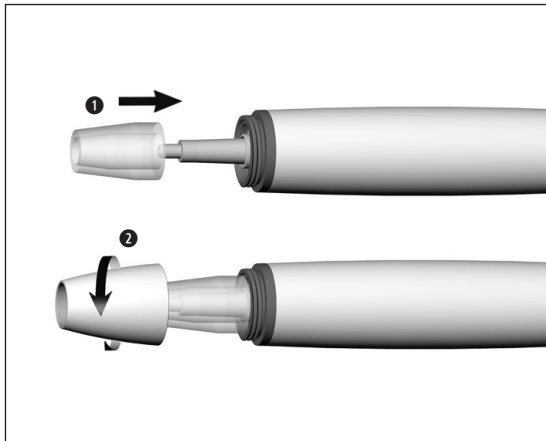

## Reassembling the medical device



Reassemble the medical device following cleaning and disinfection.

- 1 Fit optic fibre onto medical device.
- 2 Screw on the handpiece cap.



Sterilize the medical device, the tip and the tip changer following cleaning and disinfection.



Pack the medical device, the tip and the tip changer in sterilization packages that meet the following requirements:

- > The sterilization package must meet the applicable standards in respect of quality and use and must be suitable for the sterilization method.
- > The sterilization package must be large enough for the sterilization goods.
- > The filled sterilization package must not be under tension.



W&H recommends sterilization according to EN 13060, EN 285 or ANSI/AAMI ST79.



- > Read the notes, follow the instructions and heed the warnings provided by the manufacturers of steam sterilizers.
- > The program selected must be suitable for the medical device.



- > Only sterilize the tip in the tip changer. This does not include tips which are replaced using the spanner.

## Recommended sterilization cycles

- > Steam sterilization (type B, S, N)
- > Sterilization time at least 3 minutes at 134°C (273°F), 4 minutes at 132°C (270°F), 30 minutes at 121°C (250°F)
- > Maximum sterilization temperature 135°C (275°F)



Evidence of the basic suitability of the medical device, the tip and the tip changer for effective sterilization was provided by an independent test laboratory using the LISA 517 B17L steam sterilizer (W&H Sterilization S.r.l., Brusaporto (BG)), the Systec VE-150 steam sterilizer (Systec) and the CertoClav MultiControl MC2-S09S273 steam sterilizer (CertoClav GmbH, Traun).

“Dynamic-air-removal prevacuum cycle” (type B): temperature 134°C (273°F) – 3 minutes\*  
temperature 132°C (270°F) – 4 minutes\*/\*\*

“Steam-flush pressure-pulse cycle” (type S): temperature 134°C (273°F) – 3 minutes\*

“Gravity-displacement cycle” (type N): temperature 121°C (250°F) – 30 minutes\*\*

\* EN 13060, EN 285, ISO 17665

\*\* ANSI/AAMI ST55, ANSI/AAMI ST79

### **Before starting operation again**



- > Wait until the medical device is completely dry.
- > Moisture in the medical device can lead to a malfunction! (Risk of short circuit)
- > Wait until the tip, the tip changer and the spanner have completely cooled down. (Risk of burning)



- > Store sterile goods dust-free and dry.
- > The shelf life of the sterile goods depends on the storage conditions and type of packaging.

## 6. Exchanging the supply hose O-rings



- ❶ Remove O-rings.
- ❷ Slide on the new O-rings with a pair of tweezers.



Always change all O-rings to ensure tightness.

## 7. Servicing

---

### Repairs and returns

In the event of operating malfunctions immediately contact an authorized W&H service partner.

Repairs and maintenance work must only be undertaken by an authorized W&H service partner.



> Ensure that the medical device has been completely processed before returning it.



## 8. W&H Accessories and spare parts

---



Use only original W&H accessories and spare parts or accessories approved by W&H.

**Suppliers:** W&H partners

08025210 Handpiece cap and 3 optical fibres

00636901 Nozzle cleaner

02060203 O-ring for hose coupling (1 pc)

## 9. Technical data

		PB-5 L, PB-5 L S, PB-5 L Q
Max. power output to the handpiece with load (ultrasonic)	[W]	10
Frequency (ultrasonic)	[kHz]	22–35
Minimum coolant supply volume	[ml/min]	0*/20
Maximum coolant supply volume	[ml/min]	50
Water pressure	[bar]	1–6
Max. oscillating amplitude (Tip 1U)	[mm]	0.2

\* for tips where no coolant is used

**Classification according to § 6 of the General Specifications for the Safety of Medical Electrical Equipment according to IEC 60601-1/ANSI/AAMI ES 60601-1**



Type B applied part (not suitable for intracardiac application)

### **Temperature information**

Temperature of the medical device at the operator side:

maximum 71°C (159.8°F)

Temperature of the medical device at the patient side  
(front area of the medical device):

maximum 50°C (122°F)

Temperature of the medical device at the patient side  
(optical fibre):

maximum 48°C (118.4°F)

Temperature of the working part (tip):

maximum 41°C (105.8°F)

### **Ambient conditions**

Temperature during storage and transport:

-40°C to +70°C (-40°F to +158°F)

Humidity during storage and transport:

8% to 80% (relative), non-condensing

Temperature during operation:

+10°C to +35°C (+50°F to +95°F)

Humidity during operation:

15% to 80% (relative), non-condensing

Pollution level:

2

Overvoltage category:

II

Altitude:

up to 3,000 m above sea level

## 10. Disposal

---



Ensure that the parts are not contaminated on disposal.



Follow your local and national laws, directives, standards and guidelines for disposal.

- > Medical device
- > Waste electrical equipment
- > Packaging

# Explanation of warranty terms

This W&H medical device has been manufactured with great care by highly qualified specialists. A wide variety of tests and controls guarantees faultless operation. Please note that claims under warranty can only be validated when all the directions in the Instructions for use have been followed.

**As the manufacturer, W&H is liable for material or manufacturing defects within a warranty period of 24 months from the date of purchase. Accessories and consumables (tips, tip changer, nozzle cleaner) are excluded from the warranty.**

We accept no responsibility for damage caused by incorrect handling or by repairs carried out by third parties not authorized to do so by W&H!

Claims under warranty accompanied by proof of purchase must be sent to the vendor or to an authorized W&H service partner. The provision of service under warranty extends neither the warranty period nor any other guarantee period.

# 24 months warranty



## Authorized W&H service partners

---

Find your nearest authorized W&H service partner at <http://wh.com>  
Simply go to the menu option »Service« for full details.

Or simply scan the QR code.



**Manufacturer**

**W&H Dentalwerk Bürmoos GmbH**

**Ignaz-Glaser-Straße 53, 5111 Bürmoos, Austria**

**t +43 6274 6236-0,  
office@wh.com**

**f +43 6274 6236-55  
wh.com**

**Form-Nr. 51005 AEN  
Rev. 002 / 03.02.2020  
Subject to alterations**